

CHROM. 4747

An eluent programmer for column chromatography

Reproducible eluent additions are desirable for column chromatography procedures particularly when several samples are being compared. A versatile device is described which can reproducibly add eluents to a column as a series of stepwise additions or as a combination of stepwise and gradient additions. A chosen pattern can be easily modified or changed completely. The apparatus can be built with a minimum of available shop facilities and its cost is largely a function of the sophistication desired.

The versatility of this unit is due to the programmer which is used to open and close a series of relays. The programmer is basically a rotating drum with removable cams. These cams mechanically open or close a series of contacts according to a preset pattern. To prevent electrical overloading, each contact activates a relay which in turn activates a particular function of the unit for variable periods of time.

Liquid flow system

Flow from each reservoir to a manifold is controlled by an electrically operated solenoid valve (Model EDV-1-22, Fluorocarbon, Pfeifer and Co., Fort Washington, Pa.*). All connections are made with Chromatronix fittings and connecting fluid-lines are 0.16 I.D. teflon standard wall tubing. The manifold is machined from plexiglas to mate with these fittings. A bubble trap with approximately 2 ml capacity is placed after the manifold to prevent air bubbles from reaching the column. Gradients can be formed by connecting two reservoirs by the usual methods. Magnetic stirrers are positioned under the mixing reservoirs and are controlled by the electrical system.

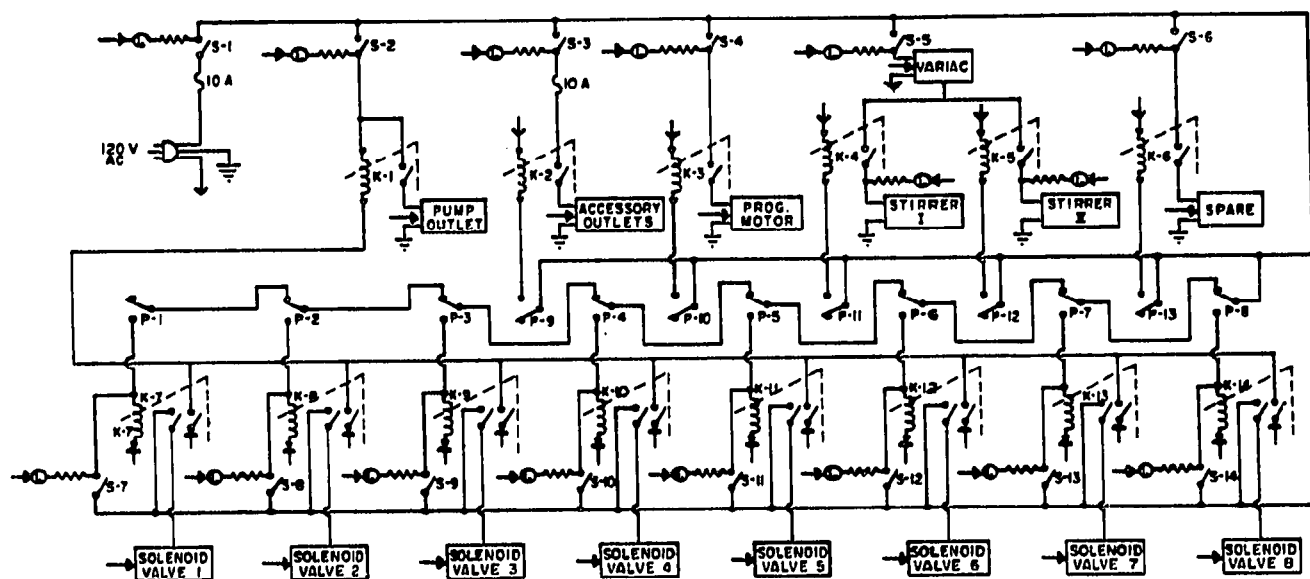

Fig. 1. Electrical schematic of eluent programmer. All resistors are 10 W, 3000 Ω . S-1 to S-14 are SPDT pushbutton switches with pilot lights. P-1 to P-13 are programmer contacts. K-1 to K-6 are Potter-Blum 5AGSPDT relays and K-7 to K-14 are Potter-Blum 11AGDPDT relays.

* Mention of commercial products does not imply their endorsement by the Department over similar products not mentioned.

Electrical system

The programmer used in this unit is a Sealectroswitch, Model No. 92-2066-203 (Sealectro Corp., Narbeth, Pa.). A one revolution per day motor is used to rotate the drum. There are 60 positions for a cam under each contact and at this speed each cam closes a contact for 24 min. Programmers can be purchased with a variety of motor speeds so that shorter time segments can be used.

Relays, activated by the programmer, are used to control each liquid flow valve, the magnetic stirrers, auxiliary outlets, pump and programmer motor. By

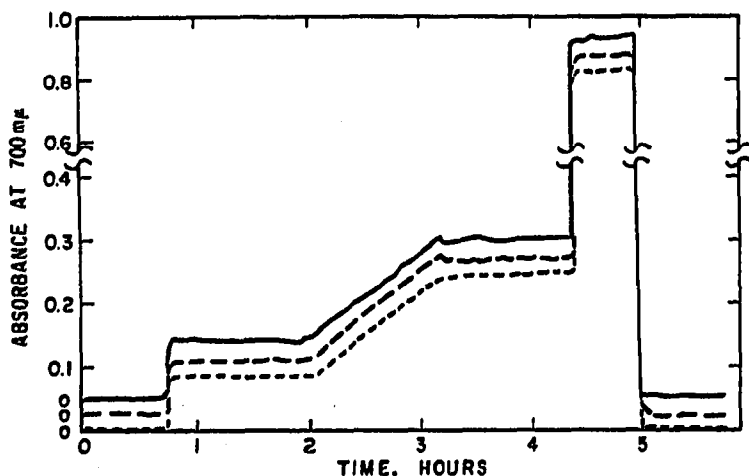

Fig. 2. Absorption of the copper sulfate solutions indicated in Fig. 3 demonstrating the reproducibility of the eluent profiles. Two of the profiles are offset from the origin to separate the runs. Flow rate was 2.4 ml/min.

controlling the latter recycling is prevented. The auxiliary outlets are used to shut down accessory equipment such as a fraction cutter, UV monitor, etc., at the end of the run.

The electrical schematic is shown in Fig. 1. There are several features of the unit which should be pointed out. Each valve may be controlled either manually or by programmed operation. The condition of each valve under either type of operation

PROGRAMMER CONTACTS

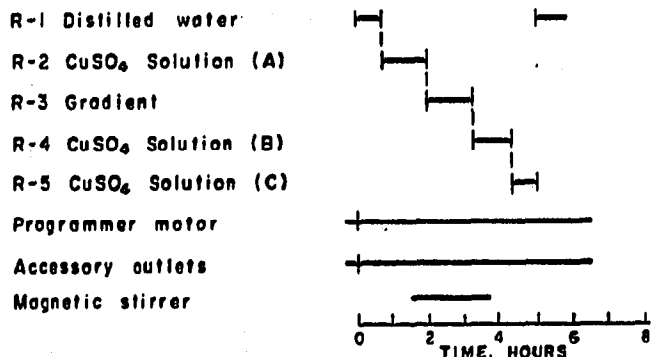

Fig. 3. Cam pattern used to program the eluent profile seen in Fig. 2. Each line indicates the period that a particular contact is closed. R-1 to R-5 are 500 ml-reservoirs. Solutions A, B and C are copper sulfate solutions with absorbances at 700 mμ of 0.1, 0.25 and 0.8, respectively; copper sulfate solutions of 1.0 and 0.1 absorbance were used to form the gradient.

is indicated by a pilot light. The pump is connected in series with the valves as a safety feature to prevent the pump from operating unless at least one valve is open. In addition the programmer is wired so that there is a simultaneous opening and closing of valves in any sequence.

Operation

To demonstrate the reproducibility and versatility of this unit a particular pattern of eluent addition, including a linear gradient, was decided upon and then matched by setting the programmer. The fluid lines and reservoirs were filled with appropriate copper sulfate solutions. Eluent absorbance at 700 m μ was monitored in a flow-through cell on a Gilford 2000 spectrophotometer. In order to make the gradient absorbance match the desired pattern the equation of BOCK AND LING¹ was used:

$$[C] = C_2 - (C_2 - C_1) \left(1 - \frac{\text{ml of eluent}}{\text{total volume of reservoirs}} \right)$$

where

[C] = concentration of gradient

C₂ = concentration of solution in 2nd reservoir

C₁ = concentration of solution in mixing reservoir.

The results of three successive runs are shown in Fig. 2. The program used is shown in Fig. 3.

*Eastern Utilization Research and Development Division,
Agricultural Research Service, United States Department
of Agriculture, 600 East Mermaid Lane,
Philadelphia, Pa. 19118 (U.S.A.)*

D. G. BAILEY

1 R. M. BOCK AND NAN-SING LING, *Anal. Chem.*, 26 (1954) 1543.

Received March 25th, 1970

J. Chromatog., 50 (1970) 137-139